



Installation instructions and maintenance information for the WHEELDOCK EZ-UP Center Stand

Thank you for choosing the **WHEELDOCK EZ-UP CENTER STAND** for Harley-Davidson touring bikes. Please take a few moments to read this instruction sheet completely.

If you have any questions, please call WheelDock at (405) 743-8080.

Your box should contain your stand, two ½-inch x 2inch long mounting bolts, two ½ inch lock washers, and two threaded square nuts with centering washers attached.

By working from the right-hand side of your bike on its side stand, you will have access to the bow-tie brace welded between the frame rails. This bow tie piece is directly under the transmission and has two large 1½ inch diameter holes. These are the mounting holes for your new center stand.

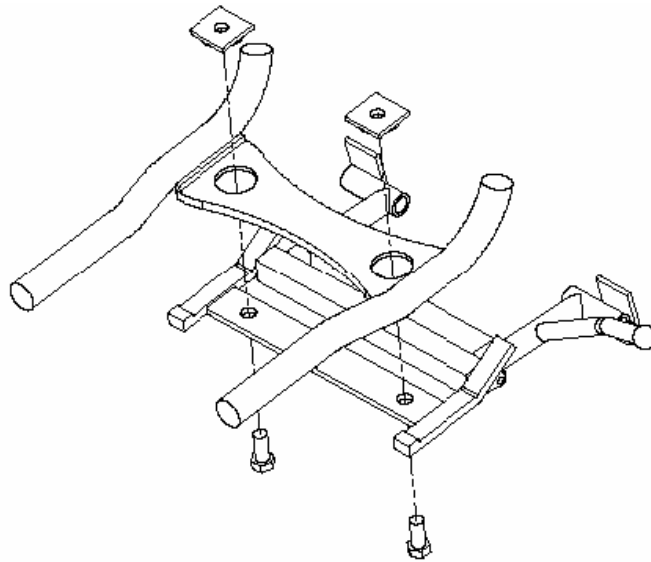

Start by slipping the square nuts over the bow tie and under the transmission so that the round centering washers fall down into the 1½ inch holes. This will assist you with getting the bolts lined up with the nuts when mounting the stand to your bike.

Install the bolts up through the stand and into the square nuts. Now tighten these bolts to about 30 ft lbs. of torque.

This center stand bears the bike's weight on the frame rails and features a zinc-plated axle, self lubricating I-Glide bushings, stainless steel springs, and tough powder coating.

The long ends of the return springs rotate with the shaft but the short ends are held stationary while the shaft rotates independently of these creating two friction points. You will need to add a bit of grease to these two friction points periodically. You will know when this is necessary when the stand returns to the up position without a free, quick return. This is the only maintenance required.

Unlike other center stands, the **WHEELDOCK EZ UP** stand requires very little effort to operate and can even be done while still on the bike by simply pushing down on the foot lever with your left foot and pulling back gently on the handlebars.

NOTE: Never attempt this with a passenger on the bike, as damage to the foot lever is possible.

You can also raise the bike on the center stand by the following traditional method:
From the left side of the bike push the foot lever down with your right foot and pull back on the bike to engage the center stand.

CAUTION: Never use your new center stand when parking on soft or uneven surfaces. If parking on an incline, make sure that the rear tire is on the downhill side so accidental roll offs are avoided.

You have two options to get the bike off the stand: You can simply rock the bike forward, or put the bike in gear and drive off.

LIMITED LIFETIME WARRANTY

WHEELDOCK, LLC (WHEELDOCK) warrants all WHEELDOCK products against defective material or workmanship for the life of the original owner, provided the purchaser promptly sends to WHEELDOCK notice of the defect and establishes that the equipment, parts, etc., have been properly set up, maintained, and operated within the limits of rated and normal usage, and provided the purchaser returns the defective part or parts to WHEELDOCK for inspection.

This Warranty shall not cover any cost of labor, transportation, freight, installation, misuse, abuse, negligence, accident, or rust, but shall be limited to repair or replacement, f.o.b. WHEELDOCK, of those parts, which upon inspection by WHEELDOCK appear to have been defective in material or workmanship.

This Warranty is limited to the first purchaser and is not transferable. Proof of purchase must accompany any returns.

This warranty is expressly in lieu of all other warranties expressed or implied (including those of merchantability and fitness of any product for a particular purpose) and all other obligations of liabilities on the part of WHEELDOCK, LLC and WHEELDOCK, LLC neither assumes nor authorizes any other person to assume for WHEELDOCK, LLC any other liability in connection with the sales of WHEELDOCK products. There are no warranties, which extend beyond the description of the face thereof.

LIMITATION OF LIABILITY

The liability of WHEELDOCK, LLC shall be limited to the repair or replacement of defective parts covered by the warranty set forth above.

Neither WHEELDOCK, NOR WHEELDOCK's dealers shall have any liability whatsoever for loss of use or for any incidental or consequential damages, such as, but not by way of limitation, loss of profits, loss of use of other equipment, improper performance of work, penalties of any kind, loss of service of personnel, or any other losses which may be experienced by the purchaser.

It is the policy of WHEELDOCK, LLC to constantly strive to improve our products. We, therefore, reserve the right to make changes in design and improvements whenever it is believed the efficiency of the product will be enhanced, without incurring any obligation to incorporate such improvements in any product, which has been shipped or is in service.